

Nyloc Insert Nut

Thread Type: UNF - Fine

Thread Direction: Right Hand

Material: Stainless Steel

Class Grade: A2-70 G304

Corrosion Protection Level: Excellent

Standard: NM Series

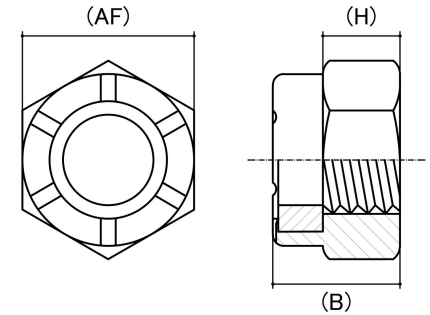

*CAD drawings shown for graphic representation only.**

Size	Thread Pitch (TPI)	Thread Type	Overall Nut Height (B) (mm)		Hex Height (H) (mm)	Across Flats (AF) (mm)		Spanner Size (AF) (inches)	sku (qfind)
			Min	Max	Nom	Min	Max		
#10-32 (3/16")	32	Fine	5.80	6.30	3.70	9.20	9.53	3/8	41NSF1032
1/4"	28	Fine	7.55	8.35	5.72	10.88	11.16	7/16	41NSF14
5/16"	24	Fine	8.35	9.10	6.35	12.43	12.76	1/2	41NSF516
3/8"	24	Fine	11.10	11.90	8.51	14.00	14.28	9/16	41NSF38
7/16"	20	Fine	11.10	11.90	8.23	15.55	15.88	5/8	41NSF716
1/2"	20	Fine	14.70	15.45	11.79	18.70	19.05	3/4	41NSF12
5/8"	18	Fine	18.67	20.00	15.07	23.42	23.83	15/16	41NSF58
3/4"	16	Fine	21.80	22.60	18.90	26.73	27.03	1-1/8	41NSF34
7/8"	14	Fine	24.60	25.40	20.07	31.48	31.81	1-5/16	41NSF78
1"	12	Fine	25.70	27.40	20.96	36.25	36.58	1-1/2	41NSF1

Disclaimer:

Dimensional data and technical information was obtained from publically available sources and not acquired through standard agencies. It has been completed and compiled for reference purposes only; where discrepancies are found they are subject to change without notice. Bolt & Nut Australia makes no warranties or representations regarding the accuracy and validity of the compiled information and data. Contact the relevant standard authorities for accurate and detailed information.

* CAD drawings may not reflect diameter, thread length or overall length.

© Bolt & Nut Australia Pty Ltd. All rights reserved.

Version: 18 Mar 2024